

SmartSlice GRT1-series I/O Terminals GRT1-DRT/ID4(-1)/OD4(-1)/ROS2/AD2/DA2C/DA2V/CT1(-1)

Downsize Control Panels, Lower Costs, and Reduce Wiring Work Compared to Conventional I/O Terminals

- Building-block design allows connection of up to 64 Remote I/O Terminals (1,024 I/O points max.).
- Easy wiring. Simply insert pin terminals (no screwdriver required).
- Replace faulty Units online and restore parameters without disconnecting I/O wiring.
- Equipped with the popular Smart functions of the DRT2 Series.
- Easy, waste-free I/O configuration when making system changes or additions.



NEW

System Configuration

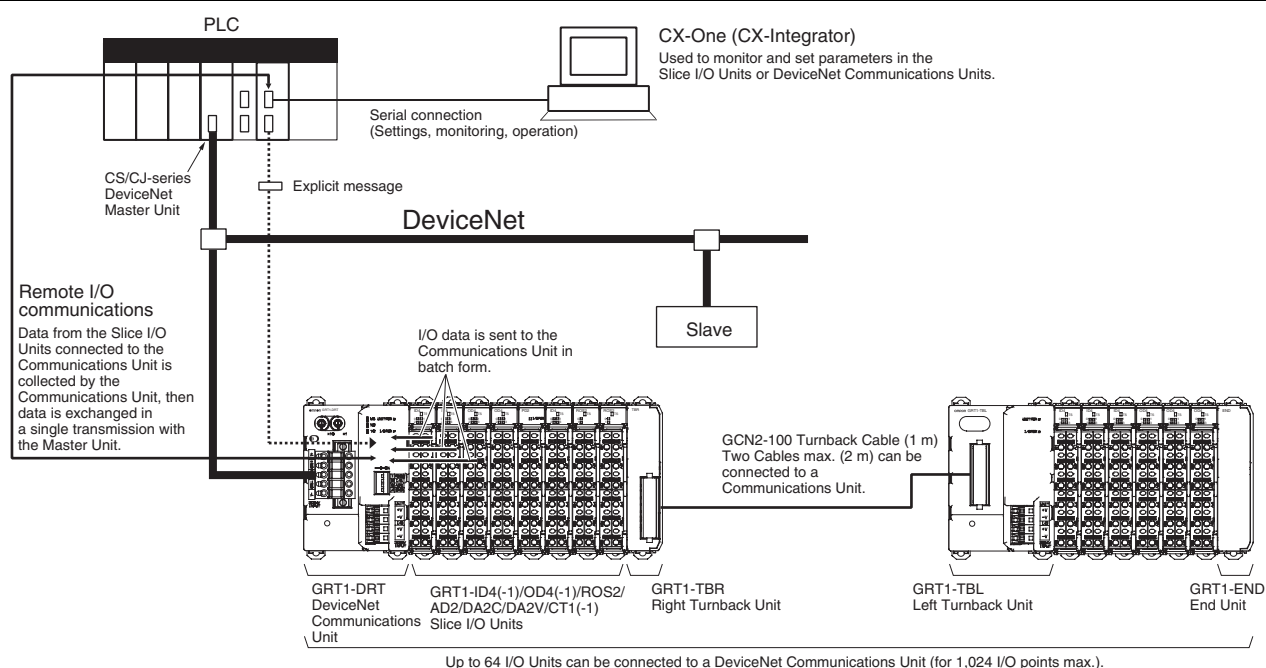

Internal Circuit Configuration

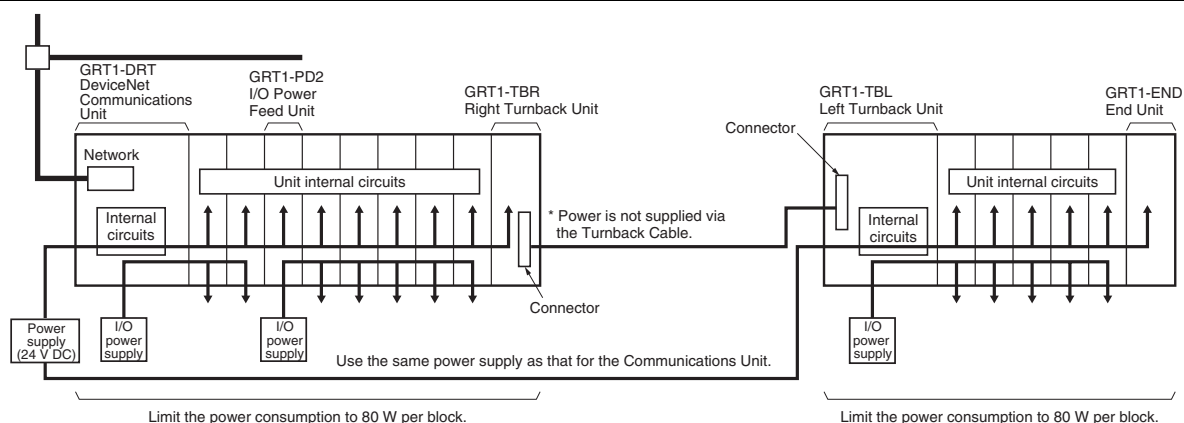

Ordering Information

Unit name		Classification	Internal I/O common	I/O points	Model	Standards (See note.)	Remarks
DeviceNet Communications Unit		---	---	---	GRT1-DRT		Up to 64 Slice I/O Units can be connected.
Slice I/O Units	Digital I/O Units	DC inputs	NPN	4 points	GRT1-ID4	UC1, CE, N, L	---
			PNP		GRT1-ID4-1		
		Transistor outputs	NPN	4 points	GRT1-OD4		
			PNP		GRT1-OD4-1		
	Relay outputs	---	2 points	GRT1-ROS2			
	Analog I/O Units	Analog inputs (current/voltage)	---	2 points	GRT1-AD2		---
		Analog outputs (current)		2 points	GRT1-DA2C		
		Analog outputs (voltage)		2 points	GRT1-DA2V		
	Counter Units	Counter	NPN	Counter inputs: 1 External outputs: 1	GRT1-CT1 <i>NEW</i>		Certification pending
PNP			GRT1-CT1-1 <i>NEW</i>				
Other Units	Turnback Units	Left Turnback	---	---	GRT1-TBR	UC1, CE, N, L	For right-side turnback
		Right Turnback	---	---	GRT1-TBL		For left-side turnback
	I/O Power Feed Unit	---	---	---	GRT1-PD2		Use when the total current consumption of the I/O Power Supply exceeds 4 A, or to make the I/O Power Supply a separate system.
	End Unit	---	---	---	GRT1-END		Necessary for terminating the Slice I/O Terminal.
	Turnback Cable	---	---	---	GCN2-100		Length: 1 m

Note: Standards:

- As of the end of January 2007, the GRT1 conforms to UL, CSA, cULus, cUL, NK, Lloyd's Register, and EC Directives (indicated as follows: U for UL, U1 for UL Class 1 Div. 2 hazardous location certification, C for CSA, UC for cULus, UC1 for cULus Class 1 Div. 2 hazardous location certification, CU for cUL, N for NK, L for Lloyd's Register, and CE for EC Directives).
- Consult your OMRON representative for details on usage conditions

Specifications

Item	Model	GRT1-DRT	GRT1-ID4(-1)	GRT1-OD4(-1)	GRT1-ROS2	GRT1-AD2	GRT1-DA2C GRT1-DA2V	GRT1-CT1(-1)
Network power supply voltage		11 to 25 V DC (Supplied from the communications connector.)	---					
Unit power supply voltage		20.4 to 26.4 V DC (24 V +10%/−15%)	20.4 to 26.4 V DC (24 V +10%/−15%) (Supplied from the Communications Unit via the Slice bus)					
I/O power supply voltage		20.4 to 26.4 V DC (See note 1.) (24 V +10%/−15%)	20.4 to 26.4 V DC (24 V +10%/−15%) (See note 2.) (Supplied from the Communications Unit or I/O Power Feed Unit via the Slice bus)			No I/O power supply		20.4 to 26.4 V DC (24 V +10%/−15%) (See note 2.) (Supplied from the Communications Unit or I/O Power Feed Unit via the Slice bus)
Noise immunity		Conforms to IEC 61000-4-4, 2 kV (power line)						
Vibration resistance		10 to 60 Hz, 0.7-mm double amplitude 60 to 150 Hz: 50 m/s ²						
Shock resistance		150 m/s ²						
Dielectric strength		500 V AC between isolated circuits						
Insulation resistance		20 MΩ min. between isolated circuits						
Ambient operating temperature		−10 to 55°C (with no icing or condensation)						
Ambient operating humidity		25% to 85%						
Ambient operating environment		No corrosive gases						
Ambient storage temperature		−25 to 65°C (with no icing or condensation)						
Mounting method		35-mm DIN track mounting						

Note: 1.For power supply input to the Slice I/O Units.
2.To drive GRT1-ROS2 Relays.

● Power Consumption and Weight

Model	Power consumption (W)	Weight (g)
GRT1-DRT	3	137
GRT1-ID4(-1)	1	76
GRT1-OD4(-1)	1	76
GRT1-ROS2	1	80
GRT1-AD2	1.5	82
GRT1-DA2C	2	82

Model	Power consumption (W)	Weight (g)
GRT1-DA2V	1.5	82
GRT1-CT1(-1)	1.1	80
GRT1-PD2	0.2	72
GRT1-TBR	0	56
GRT1-TBL	0	108
GRT1-END	0	49

GRT1-DRT DeviceNet Communications Unit

The DeviceNet Communications Unit is a DeviceNet-compliant interface for connecting the Slice I/O Units and a DeviceNet Master.

Specifications

Item	Model	GRT1-DRT
I/O points		1,024 max. (128 bytes), including inputs and outputs
Connectable Slice I/O Units		64 max.
Communications with Slice I/O Units		64 Units max. in a horizontal connection configuration (for an extension of approx. 2 m max.) (Power consumption is limited to 80 W per block, and the extension must be done using Turnback Cables (two 1-m cables max., for a distance of 2 m max.).)
Unit numbers of Slice I/O Units		1 to 64 (automatically set)
Slice I/O Unit data capacity		(1) 0, 2, or 4 bits (2) 0 to 16 words (in word increments)
Status flags		One word is allocated (Communications Unit Status Flags).
Parameter back-up and restore functions		2 Kbytes of data can be backed up and restored per Unit.
Message communications function		Supported
Automatic baud rate detection		Supported
Connector		1 DeviceNet open connector with screws Connectable with multi-drop connector.
Terminals		2 terminals for I/O power supply, 2 terminals for Unit power supply
Power supply per block		80 W max. (Unit power supply)
I/O power supply consumption current		4 A max.
Weight		137 g

Names and Functions of Parts

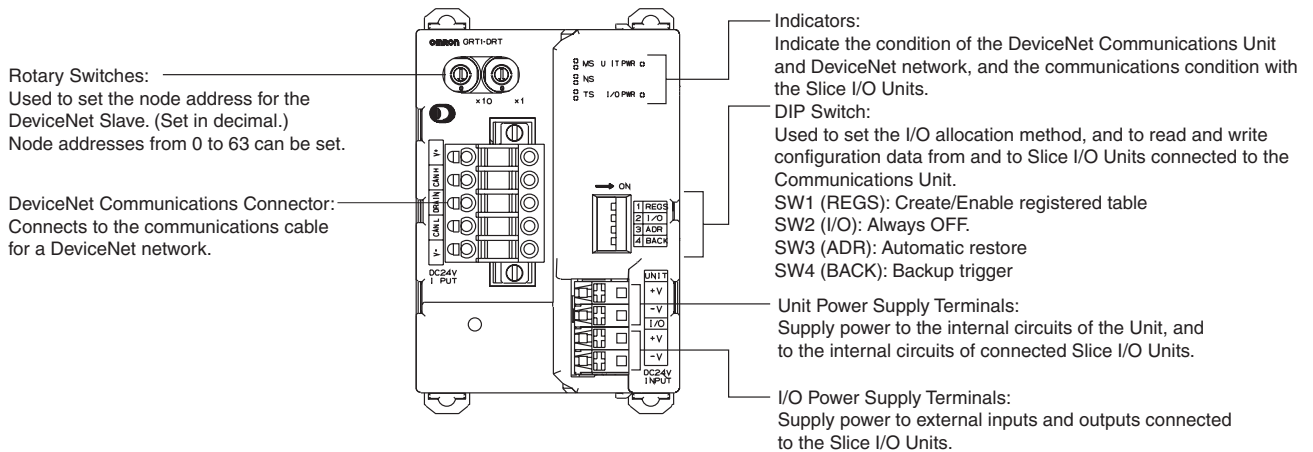

Dimensions

(Unit: mm)

GRT1-DRT

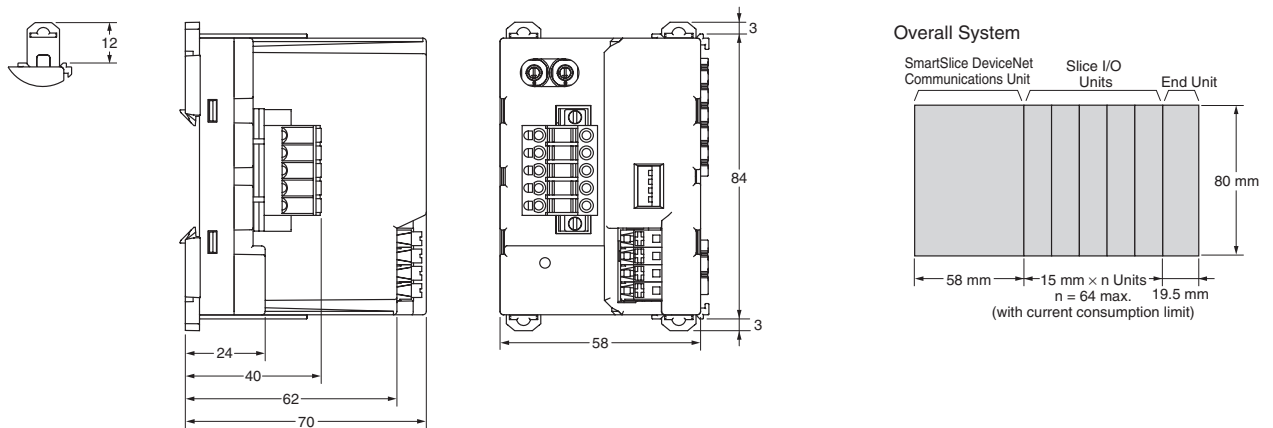

GRT1-ID4/GRT1-ID4-1 Digital Input Units (4 Points, DC Inputs)

A Slice I/O Unit performs remote I/O communications with the host via a DeviceNet Communications Unit.

Input Ratings

Item	Model	GRT1-ID4	GRT1-ID4-1
Internal I/O common		NPN	PNP
Number of inputs		4 inputs	
ON voltage		15 V DC min. between each input terminal and V	15 V DC min. between each input terminal and G
OFF voltage		5 V DC max. between each input terminal and V	5 V DC max. between each input terminal and G
OFF current		1 mA max.	
Input current		6.0 mA max./point (at 24 V DC)	
ON delay time		1.5 ms max.	
OFF delay time		1.5 ms max.	
Number of circuits/common		4 points/common	

Internal Circuit Configuration

GRT1-ID4 (NPN)

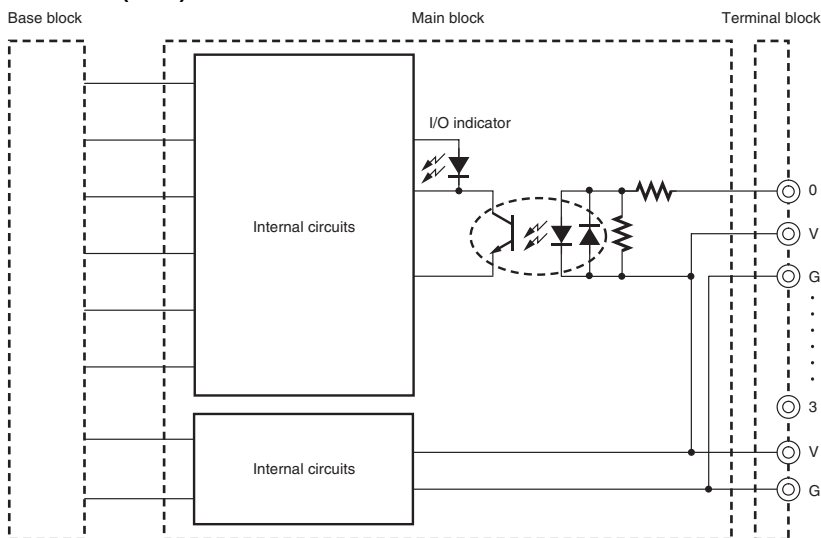

GRT1-ID4-1 (PNP)

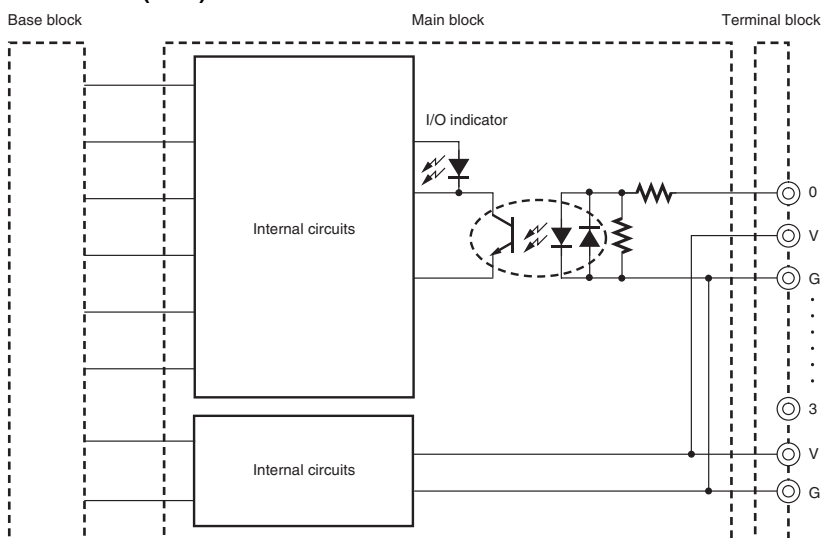

Names and Functions of Parts

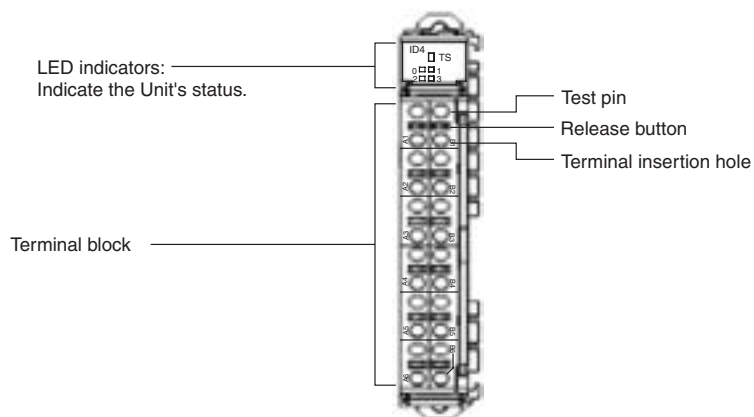

Dimensions

(Unit: mm)

GRT1-ID4
GRT1-ID4-1

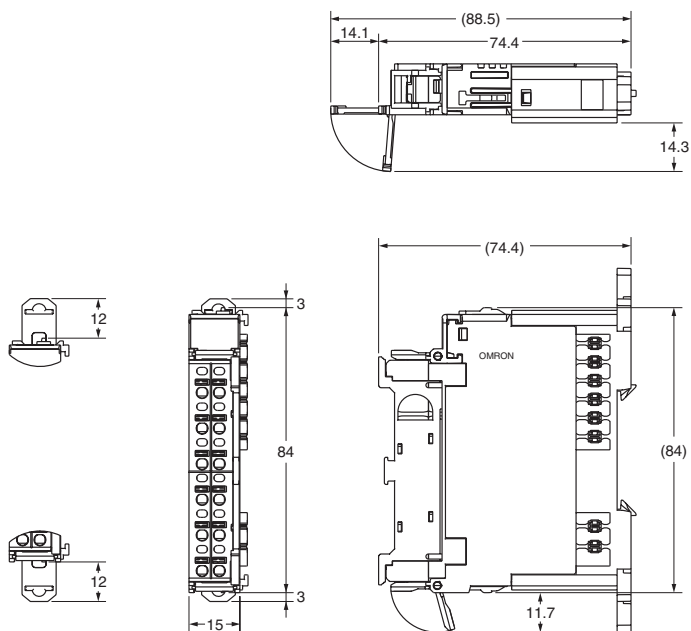

Wiring

GRT1-ID4 (NPN)

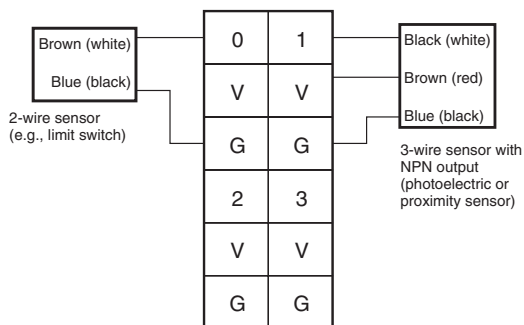

GRT1-ID4-1 (PNP)

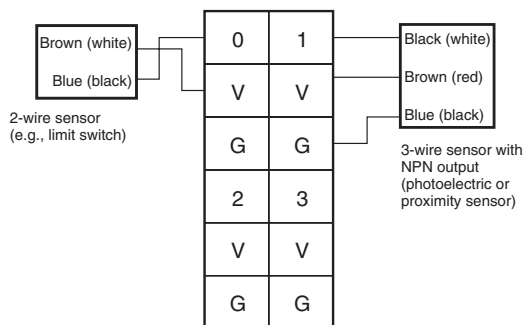

Note: Wire colors have been changed according to revisions in the JIS standards for photoelectric or proximity sensors. The previous colors are given in parentheses.

GRT1-OD4/GRT1-OD4-1 Digital Output Units (4 Points, Transistor Outputs)

Output Ratings

Item	Model	GRT1-OD4	GRT1-OD4-1
Internal I/O common		NPN	PNP
Number of outputs		4 outputs	
Rated output current		0.5 A/point	
Residual voltage		1.2 V max. (0.5 A DC between output and G terminal)	1.2 V max. (0.5 A DC between output and V terminal)
Leakage current		0.1 mA max.	
ON delay time		0.5 ms max.	
OFF delay time		1.5 ms max.	
Number of circuits per common		4 points/common	

Internal Circuit Configuration

GRT1-OD4 (NPN)

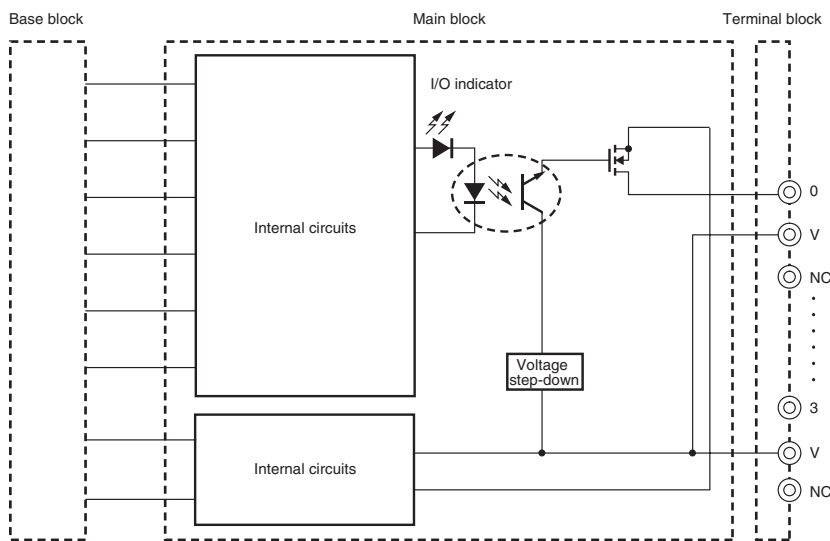

GRT1-OD4-1 (PNP)

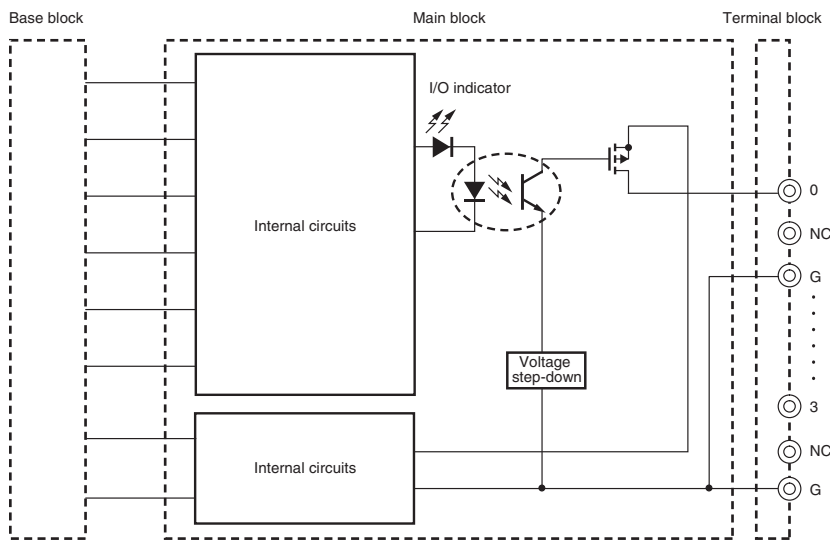

Names and Functions of Parts

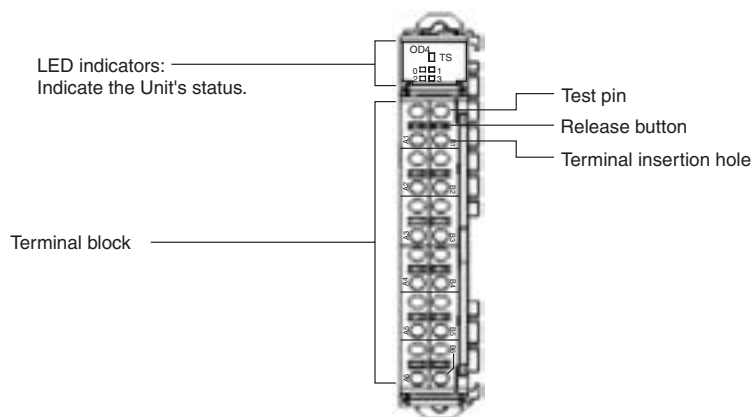

Dimensions

(Unit: mm)

GRT1-OD4
GRT1-OD4-1

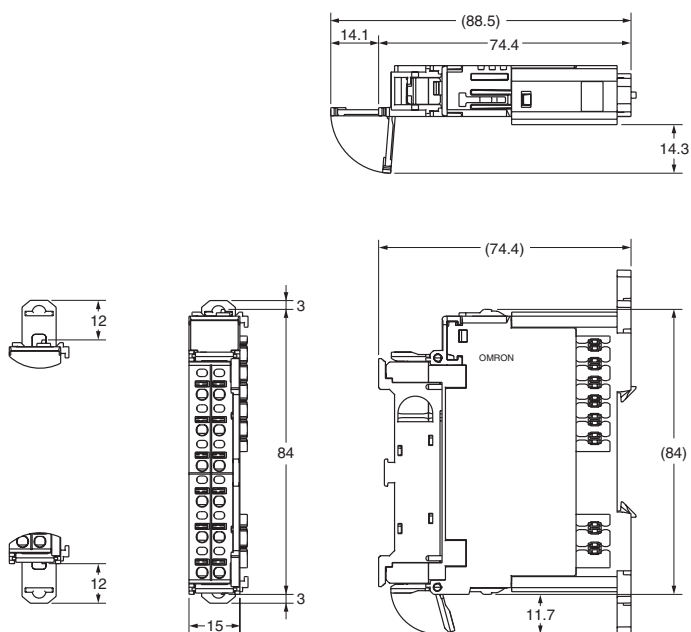

Wiring

GRT1-OD4 (NPN)

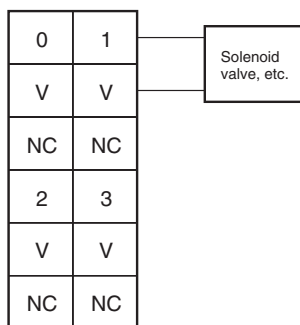

GRT1-OD4-1 (PNP)

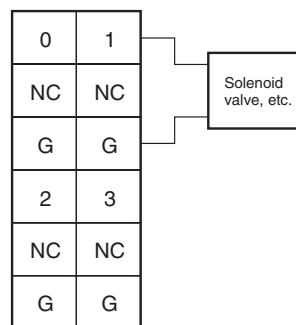

GRT1-ROS2 Relay Output Unit (2 Points, Relay Outputs)

Output Ratings

Relay	FTR-MYPA018D (Fujitsu Component, Ltd.)
Maximum switching capacity	250 V AC, 2 A; 24 V DC, 2 A
Minimum switching capacity	5 V DC, 1 mA
ON response time	15 ms max.
OFF response time	15 ms max.

● **Relay Life Expectancy**

Mechanical life expectancy	20,000,000 times min.
Electrical life expectancy	100,000 times min.

Internal Circuit Configuration

GRT1-ROS2

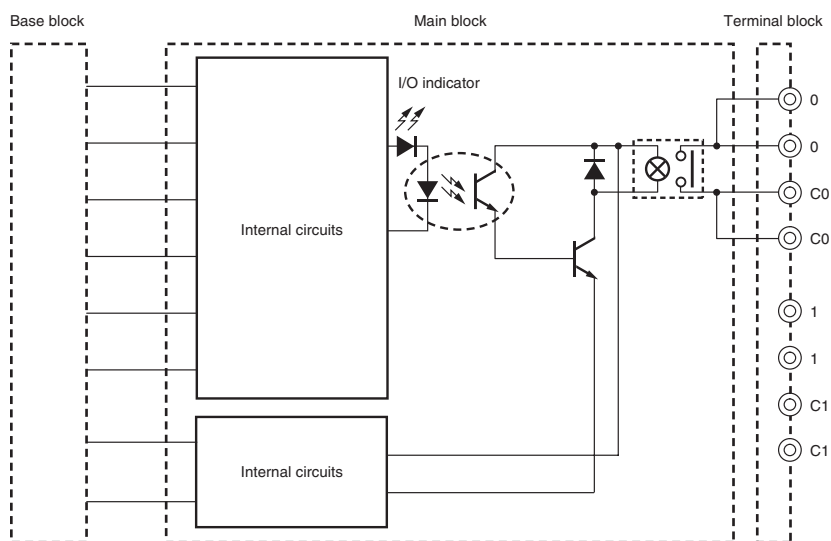

Names and Functions of Parts

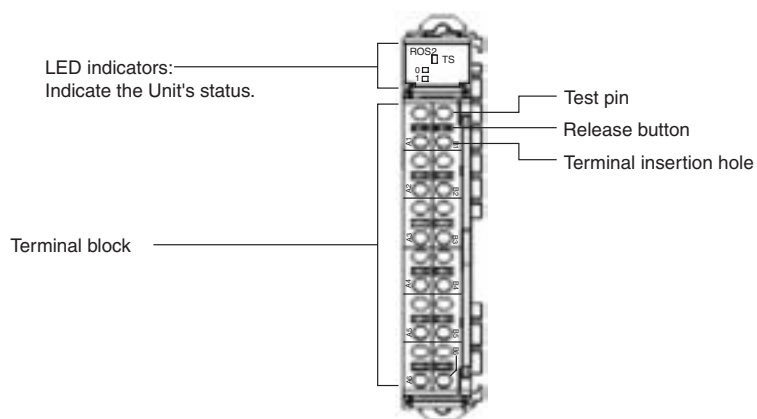

Dimensions

(Unit: mm)

GRT1-ROS2

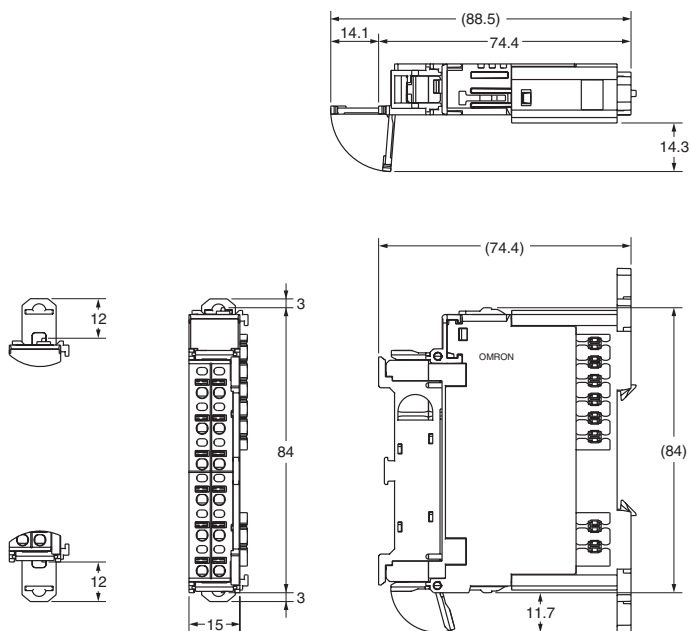

Wiring

GRT1-ROS2

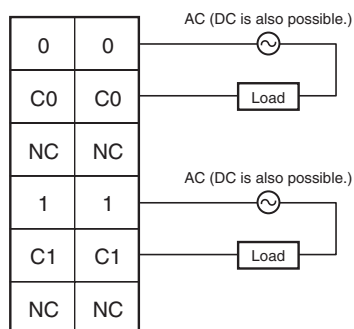

GRT1-AD2 Analog Input Unit

Characteristics

Item	Setting	Voltage input	Current input
Input points		2 (inputs 0 and 1)	
Input range (signals)		0 to 5 V, 1 to 5 V, 0 to 10 V, -10 to 10 V	0 to 20 mA, 4 to 20 mA
Input range setting method		<ul style="list-style-type: none"> • DIP switch: Inputs 0 and 1 share common settings • Setting software: Inputs 0 and 1 can be set individually. 	
Maximum signal input		±15 V	±30 mA
Input impedance		1 M Ω min.	Approx. 250 Ω
Resolution		1/6,000 (full scale)	
Overall accuracy	25°C	±0.3 FS	±0.4 FS
	-10 to 55°C	±0.6 FS	±0.8 FS
Analog conversion cycle		Using two points: 2 ms max. (without calculations)	
AD conversion data		Not ±10 V: 0000 to 1770 hex full scale (0 to 6000) ±10 V: F448 to 0BB8 hex full scale (-3000 to 3000) AD conversion range: Range ±5% FS	
Isolation method		Photocoupler isolation (between input and communications lines) There is no isolation, however, between input signals.	
I/O connection method		Screwless clamp terminal block	

Internal Circuit Configuration

GRT1-AD2

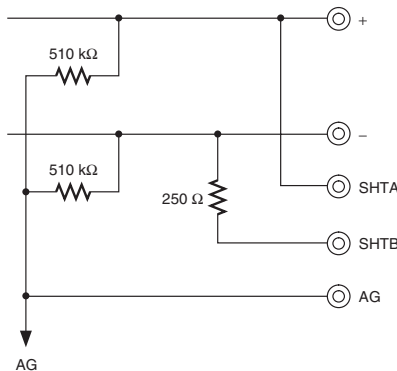

Names and Functions of Parts

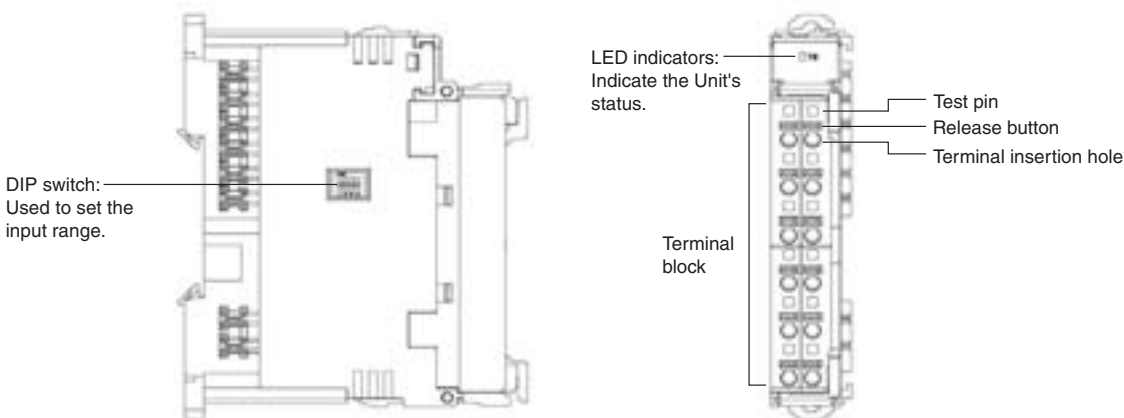

Dimensions

(Unit: mm)

GRT1-AD2

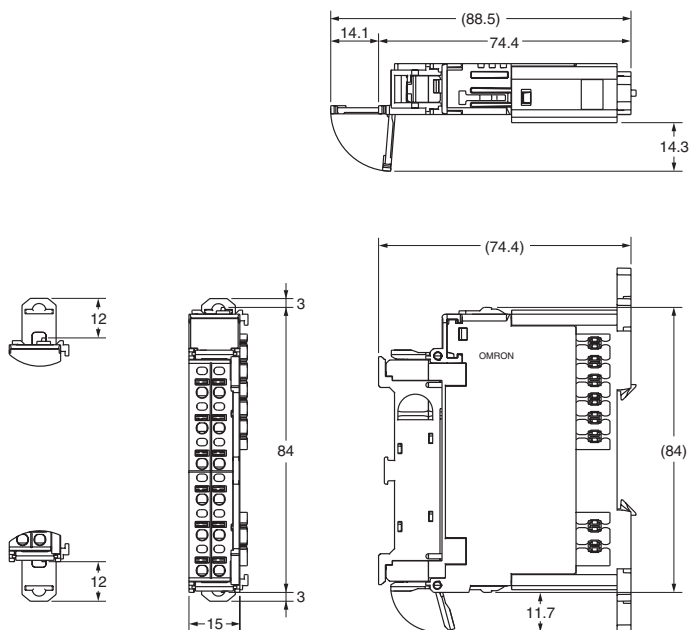

Wiring

● Voltage Input

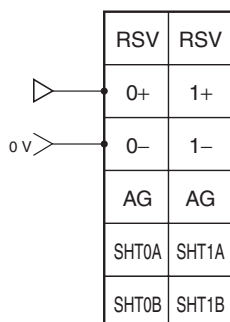

Note: Do not wire the RSV terminals.

● Current Input

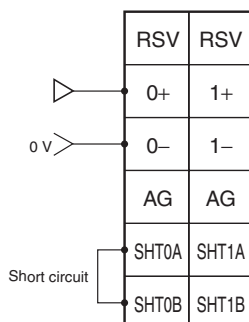

Note: 1. Do not short-circuit the SHT0A and SHT0B terminals to each other when current input is used. To perform short circuiting, use the accessory short-circuit tool.
2. Do not wire the RSV terminals.

GRT1-DA2C/GRT1-DA2V Analog Output Units

Characteristics

Items	Model	GRT1-DA2C (current output)	GRT1-DA2V (voltage output)
Output points		2 (outputs 0 and 1)	
Output type		0 to 20 mA, 4 to 20 mA	0 to 5 V, 1 to 5 V, 0 to 10 V, -10 to 10 V
Output range setting method		<ul style="list-style-type: none"> • DIP switch: Outputs 0 and 1 share common settings • Setting software: Outputs 0 and 1 can be set individually. 	
External output allowable load resistance		350 Ω max.	5 kΩ min.
Resolution		1/6,000 (full scale)	
Overall accuracy	25°C	±0.4 FS (See note.)	±0.4 FS
	-10 to 55°C	±0.8 FS (See note.)	±0.8 FS
Conversion time		2 ms/2 points	
DA conversion data		Not ±10 V: 0000 to 1770 hex full scale (0 to 6000) ±10 V: F448 to 0BB8 hex full scale (-3000 to 3000) DA conversion range: Range ±5% FS	
Isolation method		Photocoupler isolation (between output and communications lines) There is no isolation, however, between output signals.	
I/O connection method		Screwless clamp terminal block	

Note: In the 0 to 20 mA mode, accuracy is not assured at 0.2 mA or less.

Internal Circuit Configuration

GRT1-DA2C

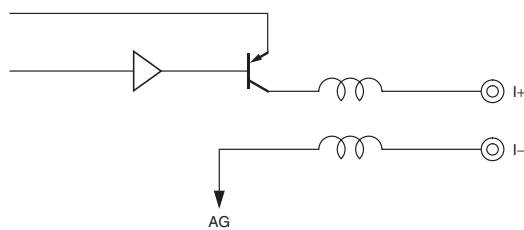

GRT1-DA2V

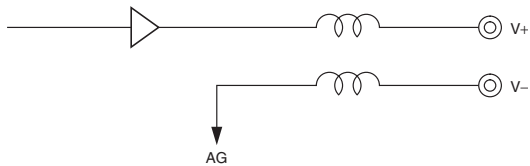

Names and Functions of Parts

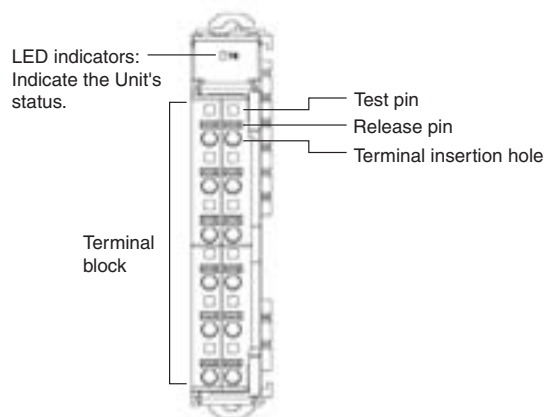
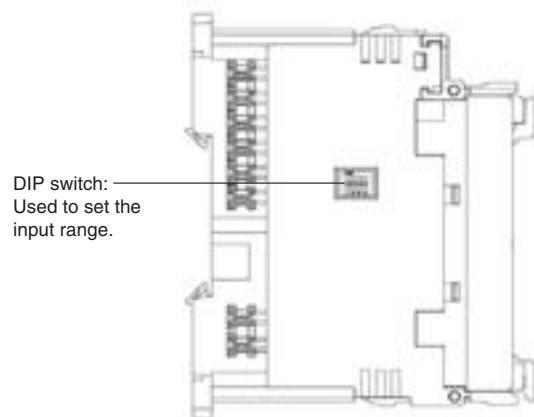

Dimensions

(Unit: mm)

GRT1-DA2C
GRT1-DA2V

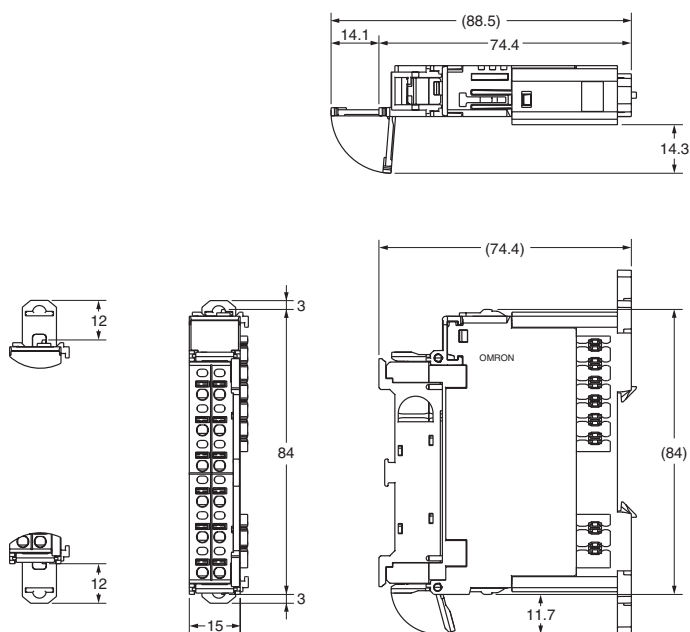

Wiring

● Current Output (GRT1-DA2C)

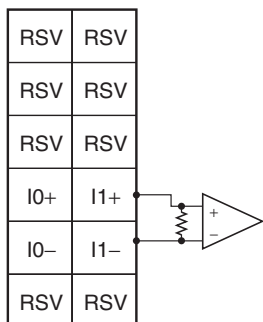

Note: Do not wire the RSV terminals.

● Voltage Output (GRT1-DA2V)

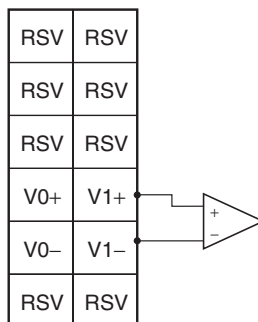

Note: Do not wire the RSV terminals.

GRT1-CT1/GRT1-CT1-1 Counter Units

Characteristics

Item	Model	Voltage input
Input signal		Phases A, B, and Z or digital input
Output signal		Digital output (setting possible)
Counter resolution		32 bits
Maximum counter input frequency		60 kHz max. depending on the counter mode
Response time		1 ms max. (See note.)
Insulation method		Photocoupler isolation (between communications lines and input/output lines). There is no isolation, however, between input signal lines and output signal lines.
I/O connection method		Screwless clamp terminal block

Note: The response time is the time between the moment the A, B, Z, or IN input turns ON or OFF and the moment the digital output is updated to the new state. The specified response time may not be achieved during monitoring or maintenance.

I/O Signal Ratings

The encoder A and B inputs are phase differential signals for counting. The encoder Z input is a reset input.

● Input Signals

Encoder Phase A Input and Phase B Input

Item	Model	GRT1-CT1	GRT1-CT1-1
Input type		NPN	PNP
Number of inputs		2 inputs (phase A/phase B encoder input)	
ON voltage		18.6 V min. between each input terminal and V	18.6 V min. between each input terminal and G
ON current		3.0 mA min.	
OFF voltage		4.0 V min. between each input terminal and V	4.0 V min. between each input terminal and G
OFF current		1.0 mA max.	

Encoder Phase Z Input or Digital Input

Item	Model	GRT1-CT1	GRT1-CT1-1
Input type		NPN	PNP
Number of inputs		1 input	
ON voltage		15.0 V min. between each input terminal and V	15.0 V min. between each input terminal and G
ON current		3.0 mA min.	
OFF voltage		5.0 V min. between each input terminal and V	5.0 V min. between each input terminal and G
OFF current		1.0 mA max.	
ON response time		1 ms max. (See note.)	
OFF response time		1 ms max. (See note.)	

Note: The response time is the time between the moment the A, B, Z, or IN input turns ON or OFF and the moment the digital output is updated to the new state. The specified response time may not be achieved during monitoring or maintenance.

● Digital Output (OUT)

Item	Model	GRT1-CT1	GRT1-CT1-1
Output type		NPN	PNP
Number of Outputs		1 output	
Total output current		500 mA max.	
Residual voltage		1.2 V max. between output terminal and G	1.2 V max. between output terminal and V
Leakage current		0.1 mA max.	
ON response time		1 ms max. (See note.)	
OFF response time		1 ms max. (See note.)	
Output short-circuit protection		None	
Off-wire detection		None	

Note: The response time is the time between the moment the A, B, Z, or IN input turns ON or OFF and the moment the digital output is updated to the new state. The specified response time may not be achieved during monitoring or maintenance.

Internal Circuit Configuration

GRT1-CT1 (NPN)

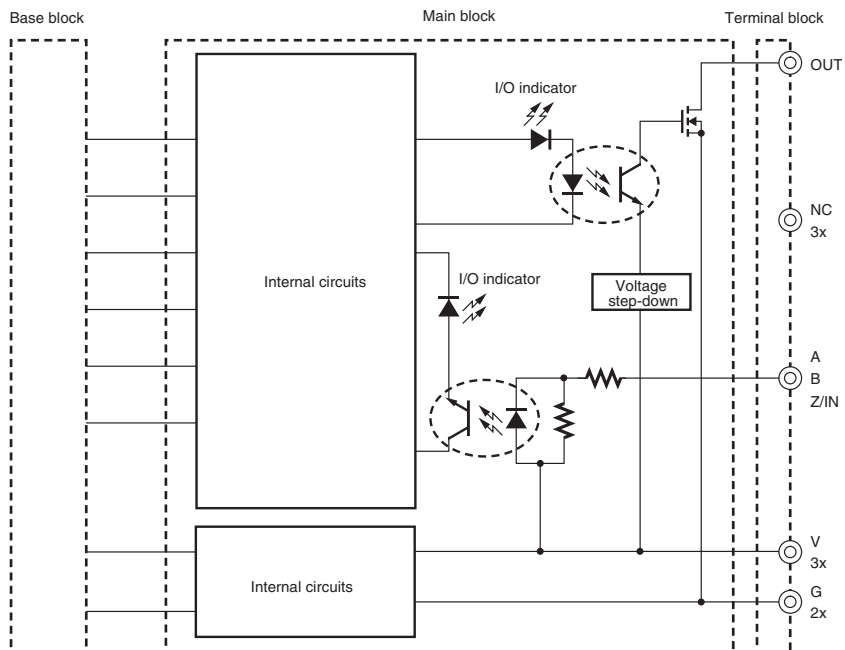

GRT1-CT1-1 (PNP)

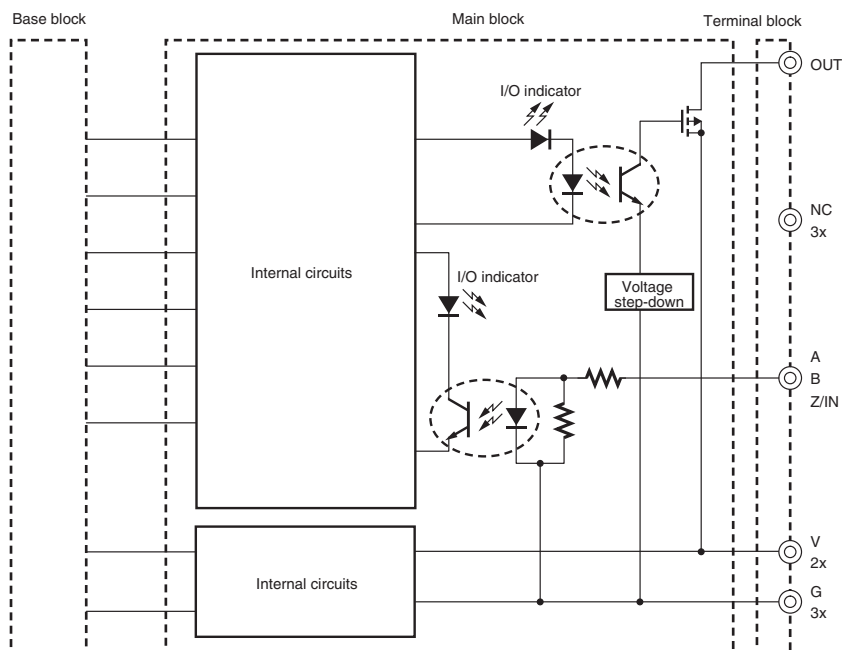

Names and Functions of Parts

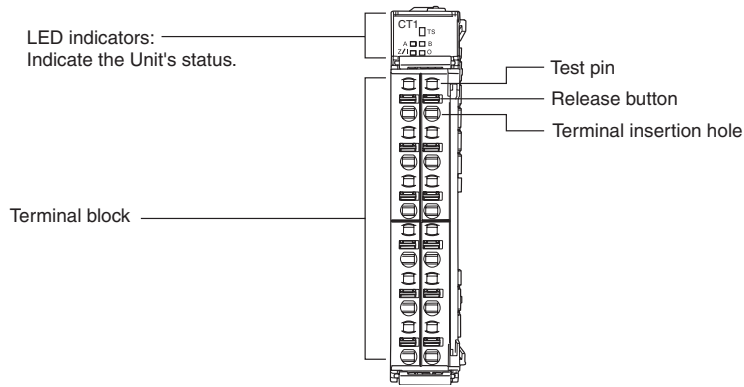

Dimensions

(Unit: mm)

GRT1-CT1
GRT1-CT1-1

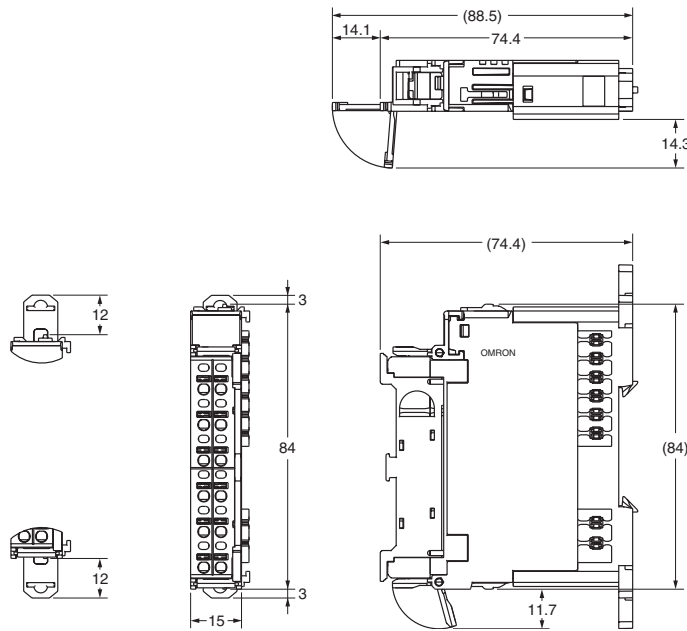

Wiring

● GRT1-CT1 (NPN)

A	OUT
B	V
Z/IN	NC
NC	NC
V	V
G	G

● GRT1-CT1-1 (PNP)

A	OUT
B	NC
Z/IN	G
NC	NC
V	V
G	G

GRT1-PD2 I/O Power Feed Unit

The I/O Power Feed Unit is used to separate the I/O power supply inside the Slice I/O Terminal, and provide a mid-system power supply.

Specifications

Power supply voltage	20.4 to 26.4 V DC (24 V DC +10%/−15%)
Current capacity	4 A

Names and Functions of Parts

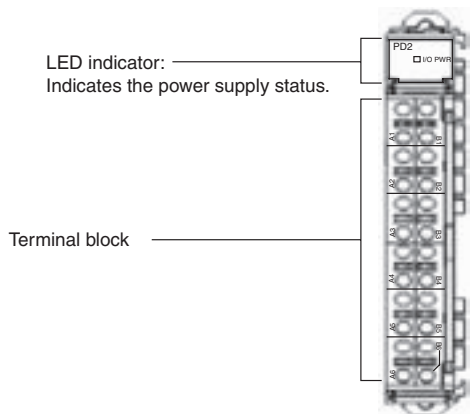

Wiring

GRT1-PD2

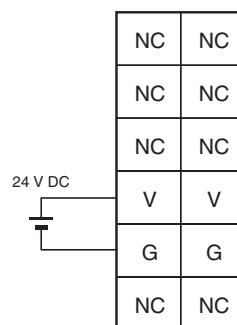

Dimensions

(Unit: mm)

GRT1-PD2

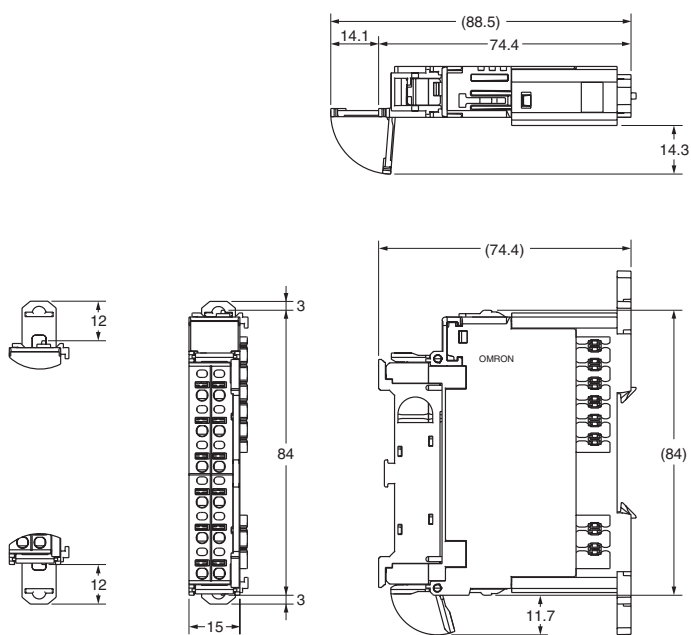

GRT1-TBR Right Turnback Unit

When dividing or expanding a Slice I/O Terminal block, this Unit is connected to the right side of the block and connected to a Left Turnback Unit (GRT1-TBL) using a Turnback Cable.

Names and Functions of Parts

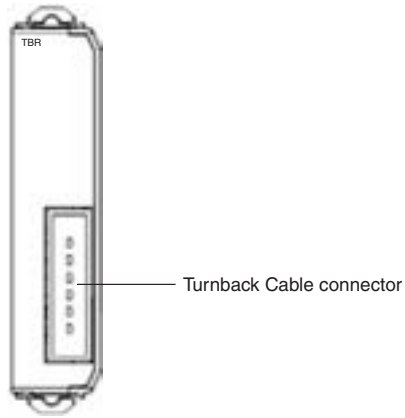

Dimensions

(Unit: mm)

GRT1-TBR

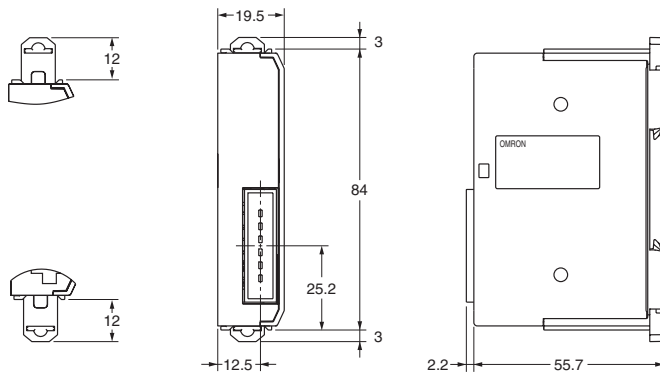

GRT1-TBL Left Turnback Unit

When dividing and expanding a Slice I/O Terminal block, this Unit is connected to the left side of the new block and connected to a Right Turnback Unit (GRT1-TBR) using a Turnback Cable.

Power is supplied to the Slice I/O Units through this Unit.

Note: Be sure that the power supply for this Unit is the same as that for the Communications Unit.

Names and Functions of Parts

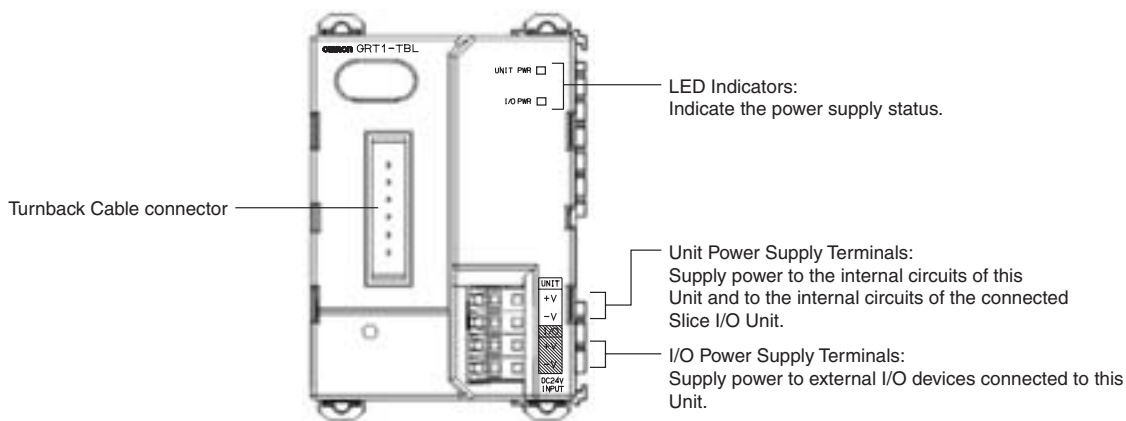

Dimensions

(Unit: mm)

GRT1-TBL

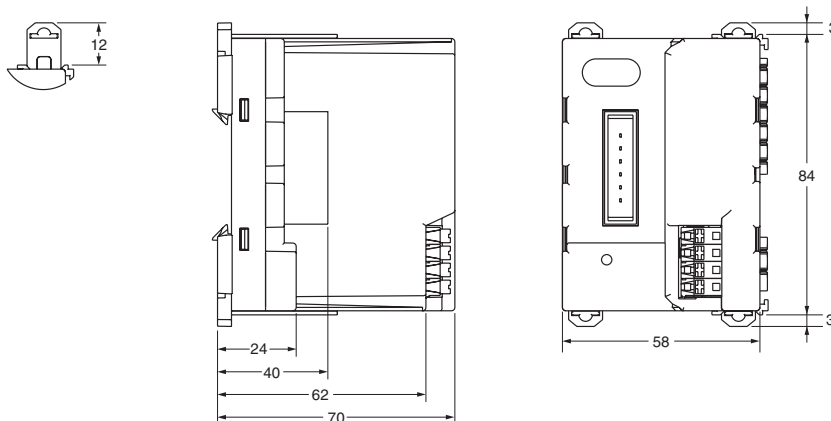

GRT1-END End Unit

The End Unit must be mounted to the end of the Slice I/O Terminal.

Dimensions

(Unit: mm)

GRT1-END

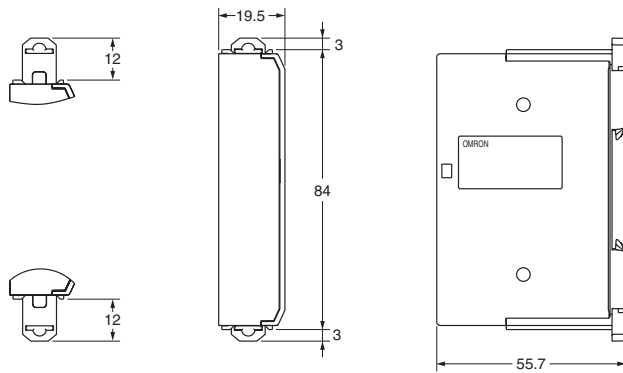

Read and Understand this Catalog

Please read and understand this catalog before purchasing the product. Please consult your OMRON representative if you have any questions or comments.

Warranty and Limitations of Liability

WARRANTY

OMRON's exclusive warranty is that the products are free from defects in materials and workmanship for a period of one year (or other period if specified) from date of sale by OMRON.

OMRON MAKES NO WARRANTY OR REPRESENTATION, EXPRESS OR IMPLIED, REGARDING NON-INFRINGEMENT, MERCHANTABILITY, OR FITNESS FOR PARTICULAR PURPOSE OF THE PRODUCTS. ANY BUYER OR USER ACKNOWLEDGES THAT THE BUYER OR USER ALONE HAS DETERMINED THAT THE PRODUCTS WILL SUITABLY MEET THE REQUIREMENTS OF THEIR INTENDED USE. OMRON DISCLAIMS ALL OTHER WARRANTIES, EXPRESS OR IMPLIED.

LIMITATIONS OF LIABILITY

OMRON SHALL NOT BE RESPONSIBLE FOR SPECIAL, INDIRECT, OR CONSEQUENTIAL DAMAGES, LOSS OF PROFITS OR COMMERCIAL LOSS IN ANY WAY CONNECTED WITH THE PRODUCTS, WHETHER SUCH CLAIM IS BASED ON CONTRACT, WARRANTY, NEGLIGENCE, OR STRICT LIABILITY.

In no event shall the responsibility of OMRON for any act exceed the individual price of the product on which liability is asserted. IN NO EVENT SHALL OMRON BE RESPONSIBLE FOR WARRANTY, REPAIR, OR OTHER CLAIMS REGARDING THE PRODUCTS UNLESS OMRON'S ANALYSIS CONFIRMS THAT THE PRODUCTS WERE PROPERLY HANDLED, STORED, INSTALLED, AND MAINTAINED AND NOT SUBJECT TO CONTAMINATION, ABUSE, MISUSE, OR INAPPROPRIATE MODIFICATION OR REPAIR.

Application Considerations

SUITABILITY FOR USE

OMRON shall not be responsible for conformity with any standards, codes, or regulations that apply to the combination of the product in the customer's application or use of the product.

Take all necessary steps to determine the suitability of the product for the systems, machines, and equipment with which it will be used. Know and observe all prohibitions of use applicable to this product.

NEVER USE THE PRODUCT FOR AN APPLICATION INVOLVING SERIOUS RISK TO LIFE OR PROPERTY WITHOUT ENSURING THAT THE SYSTEM AS A WHOLE HAS BEEN DESIGNED TO ADDRESS THE RISKS, AND THAT THE OMRON PRODUCT IS PROPERLY RATED AND INSTALLED FOR THE INTENDED USE WITHIN THE OVERALL EQUIPMENT OR SYSTEM.

PROGRAMMABLE PRODUCTS

OMRON shall not be responsible for the user's programming of a programmable product, or any consequence thereof.

Disclaimers

CHANGE IN SPECIFICATIONS

Product specifications and accessories may be changed at any time based on improvements and other reasons. Consult with your OMRON representative at any time to confirm actual specifications of purchased product.

DIMENSIONS AND WEIGHTS

Dimensions and weights are nominal and are not to be used for manufacturing purposes, even when tolerances are shown.

PERFORMANCE DATA

Performance data given in this catalog is provided as a guide for the user in determining suitability and does not constitute a warranty. It may represent the result of OMRON's test conditions, and the users must correlate it to actual application requirements. Actual performance is subject to the OMRON Warranty and Limitations of Liability.

ALL DIMENSIONS SHOWN ARE IN MILLIMETERS.

To convert millimeters into inches, multiply by 0.03937. To convert grams into ounces, multiply by 0.03527.

Cat. No. R139-E1-02

In the interest of product improvement, specifications are subject to change without notice.

OMRON Corporation

**Industrial Automation Company
Control Devices Division H.Q.**

Shiokoji Horikawa, Shimogyo-ku,
Kyoto, 600-8530 Japan
Tel: (81)75-344-7109
Fax: (81)75-344-7149

Regional Headquarters

OMRON EUROPE B.V.

Wegalaan 67-69, NL-2132 JD Hoofddorp
The Netherlands
Tel: (31)2356-81-300
Fax: (31)2356-81-388

OMRON ELECTRONICS LLC

One Commerce Drive Schaumburg,
IL 60173-5302 U.S.A.
Tel: (1) 847-843-7900/Fax: (1) 847-843-7787

OMRON ASIA PACIFIC PTE. LTD.

No. 438A Alexandra Road # 05-05/08 (Lobby 2),
Alexandra Technopark, Singapore 119967
Tel: (65) 6835-3011/Fax: (65) 6835-2711

OMRON (CHINA) CO., LTD.

Room 2211, Bank of China Tower,
200 Yin Cheng Zhong Road,
Pu Dong New Area, Shanghai, 200120, China
Tel: (86) 21-5037-2222/Fax: (86) 21-5037-2200