

Line of Long-distance Photoelectric Sensors for Large Workpieces Includes Retro-reflective Models with Sensing Distance of 10 m and Distance Settings Up to 2 m.

- Compact Retro-reflective models require less wiring and less space with a sensing distance as long as 10 m.
- Distance-setting models feature a teaching function.
- Stability indicator shows at a glance when operating conditions are stable.
- Relay and selectable NPN/PNP transistor outputs provided.
- Cable, standard connector, and terminal board models available.



Be sure to read *Safety Precautions* on page 8.

Ordering Information

Sensors (Refer to *Dimensions* on page 10.)

Red light Infrared light

Sensing method	Appearance	Connection method	Sensing distance	Timer function	Model	
					NPN/PNP selector	Relay output
Retro-reflective (with MSR function)		Pre-wired (2 m)		---	E3G-R13 2M	---
		Connector (M12)			E3G-R17	
		Terminal block			---	
				Yes	---	E3G-MR19T
Distance-setting		Pre-wired (2 m)	White paper (300 × 300 mm) 	---	E3G-L73 2M	---
		Connector (M12)			E3G-L77	
		Terminal block			---	
				Yes	---	E3G-ML79T

* Values in parentheses indicate the minimum required distance between the Sensor and Reflector.

Accessories (Order Separately)

Reflectors (Refer to *Dimensions* on E39-L/F39-L/E39-S/E39-R.)



Appearance	Sensing distance (typical)	Model	Minimum order	Remarks
	10 m (500 mm) (Rated value)*	E39-R2	1	Provided with the E3G-R1□/MR19(T).
	6 m (100 mm)*	E39-R1	1	---

* Values in parentheses indicate the minimum required distance between the Sensor and Reflector.

Terminal Protection Cover for Side-pullout Cable (Refer to *Dimensions* on page 12.)

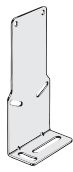
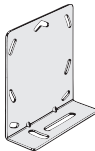

Appearance	Model	Minimum order	Applicable model	Remarks
	E39-L129	1	E3G-MR19(T) E3G-ML79(T)	Provided with rubber bushing and cap for pullout prevention in vertical direction.

Mounting Brackets (Refer to E39-L/F39-L/E39-S/E39-R)

Appearance	Model	Quantity	Applicable model	Remarks
	E39-L131	1	E3G-R1□ E3G-L7□	---
	E39-L132	1		Rear-mounting use
	E39-L135	1	E3G-MR19(T) E3G-ML79(T)	Cable pulled out in the downward direction
	E39-L136	1		---

Note: Mounting Brackets are not provided with Sensors and must be purchased separately.

Sensor I/O Connectors (M12) (Refer to Dimensions on XS2.)

Cable	Appearance	Cable type		Model	
Standard	Straight		2 m	Three-conductor type	XS2F-D421-DC0-A
			5 m		XS2F-D421-GC0-A
	L-shaped		2 m		XS2F-D422-DC0-A
			5 m		XS2F-D422-GC0-A

Note: Refer to *Introduction to Sensor I/O Connectors* for details.

Ratings and Specifications

Sensing method		Retro-reflective (with MSR function)				Distance-setting			
Item	Model	E3G-R13	E3G-R17	E3G-MR19	E3G-MR19T	E3G-L73	E3G-L77	E3G-ML79	E3G-ML79T
Sensing distance		10 m (500 mm)*1 (when using E39-R2)				White paper (300 x 300 mm): 0.2 to 2 m			
Setting distance		---				White paper (300 x 300 mm): 0.5 to 2 m			
Standard sensing object		Opaque: 80-mm dia. min.				---			
Differential travel (typical)		---				10% of setting distance			
Directional angle		Sensor: 1° to 5°				---			
Reflectivity characteristics (black/white error)		---				±10% max. (at 1-m sensing distance)			
Light source (wavelength)		Red LED (650 nm)				Infrared LED (860 nm)			
Spot size		---				70 dia. max. (at 1-m sensing distance)			
Power supply voltage		10 to 30 VDC, ripple (p-p): 10%		12 to 240 VDC±10%, ripple (p-p): 10% max. 24 to 240 VAC±10% at 50/60 Hz		10 to 30 VDC, ripple (p-p): 10% (p-p)		12 to 240 VDC±10%, ripple (p-p): 10% max. 24 to 240 VAC±10% at 50/60 Hz	
Current/Power consumption		50 mA max.		2 W max.		60 mA max.		2 W max.	
Control output		Load power supply voltage: 30 VDC max. Load current: 100 mA max. Residual voltage: NPN output: 1.2 V max. PNP output: 2.0 V max. Open collector output (NPN/PNP selectable) L.ON/D.ON selectable		Relay output: SPDT, 3 A (cosφ= 1) max. at 250 VAC or 3 A max. at 30 VDC L.ON/D.ON selectable		Load power supply voltage: 30 VDC max. Load current: 100 mA max. Residual voltage: NPN output: 1.2 V max. PNP output: 2.0 V max. Open collector output (NPN/PNP selectable) L.ON/D.ON selectable		Relay output: SPDT, 3 A (cosφ= 1) max. at 250 VAC or 3 A max. at 30 VDC L.ON/D.ON selectable	
Life expectancy (relay output)	Mechanical	---		50,000,000 operations min. (switching frequency: 18,000 operations/h)		---		50,000,000 operations min. (switching frequency: 18,000 operations/h)	
	Electrical	---		100,000 operations min. (switching frequency: 1,800 operations/h)		---		100,000 operations min. (switching frequency: 1,800 operations/h)	
Protection circuits		Power supply reverse polarity protection, Output short-circuit protection, Mutual interference prevention		Mutual interference prevention		Power supply reverse polarity protection, Output short-circuit protection, Mutual interference prevention		Mutual interference prevention	
Response time		Operate or reset: 1 ms		Operate or reset: 30 ms max.		Operate or reset: 5 ms		Operate or reset: 30 ms max.	
Sensitivity adjustment		One-turn adjuster				Teaching (in NORMAL or ZONE mode)			
Timer function		---		ON- or OFF-delay: 0 to 5 s (adjustable)		---		ON- or OFF-delay: 0 to 5 s (adjustable)	
Ambient illumination (Receiver side)		Incandescent lamp: 3,000 lx max. Sunlight: 10,000 lx max.							
Ambient temperature range		Operating: -25° to 55°C, Storage: -30° to 70°C (with no icing or condensation)							
Ambient humidity range		Operating: 35% to 85%, Storage: 35% to 95% (with no condensation)							
Insulation resistance		20 MΩ min. at 500 VDC							
Dielectric strength		1,000 VAC, 50/60 Hz for 1 min		2,000 VAC, 50/60 Hz for 1 min.		1,000 VAC, 50/60 Hz for 1 min		2,000 VAC, 50/60 Hz for 1 min.	
Vibration resistance		Destruction: 10 to 55 Hz, 1.5-mm double amplitude for 2 hours each in X, Y, and Z directions							
Shock resistance		Destruction: 500 m/s ² 3 times each in X, Y, and Z directions							
Degree of protection		IEC 60529 IP67 (with protective cover)							
Connection method		Pre-wired (Standard length: 2 m)	Connector (M12)	Terminal block		Pre-wired (Standard length: 2 m)	Connector (M12)	Terminal block	
Weight (packed state)		Approx. 150 g	Approx. 50 g	Approx. 150 g			Approx. 50 g	Approx. 150 g	
Material	Case	PBT (polybutylene terephthalate)							
	Lens	Mechacrylic resin							
Accessories *2		Reflector, Adjustment screwdriver, and Instruction manual				Adjustment screwdriver and Instruction manual			

*1. Values in parentheses indicate the minimum required distance between the Sensor and Reflector.

*2. Mounting Brackets are sold separately.

Engineering Data (Typical)

E3G-R/MR Retro-reflective Models

Excess Gain vs. Set Distance

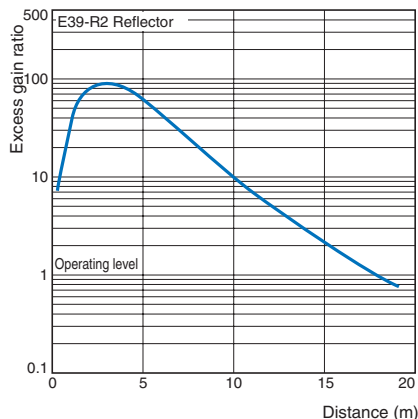

Parallel Operating Range

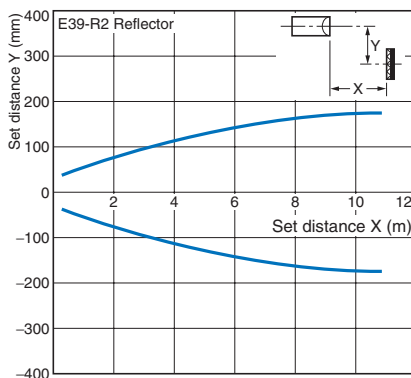

E3G-L/ML Distance-setting Models

Spot Diameter vs. Sensing Distance

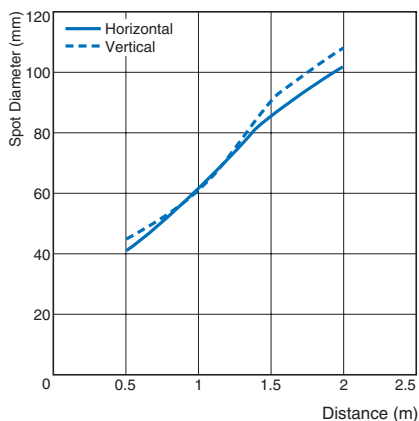

Operating Range in NORMAL Mode

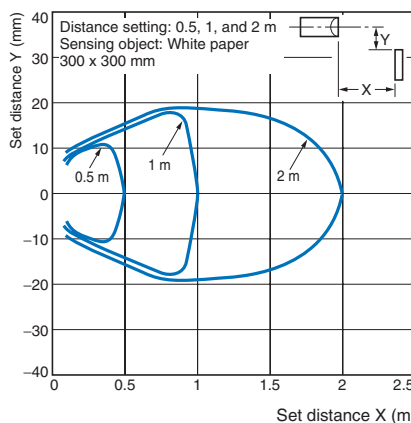

Operating Range in ZONE Mode

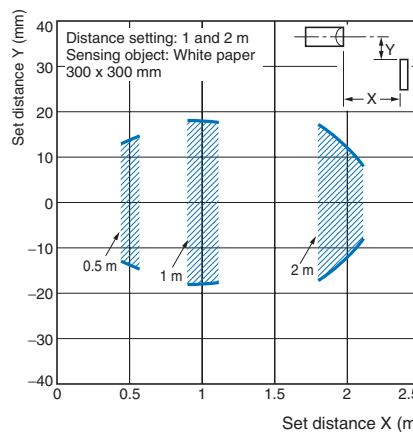

Sensing Object Size vs. Setting Distance

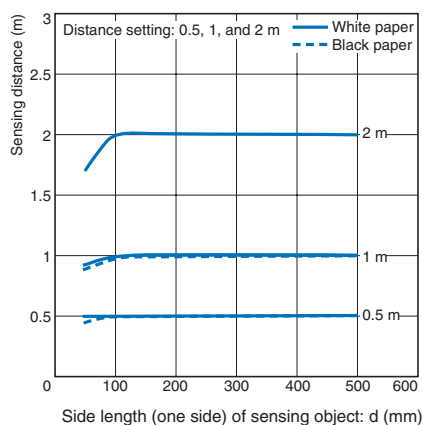

Sensing Object Angle Characteristics (Vertical)

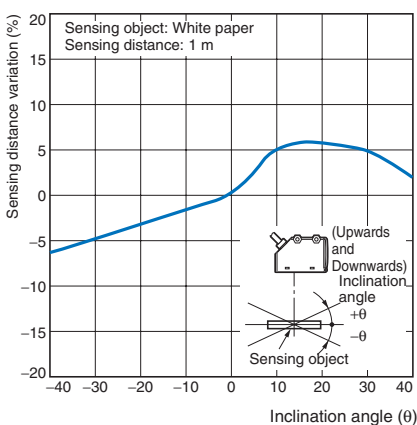

Sensing Object Angle (Horizontal)

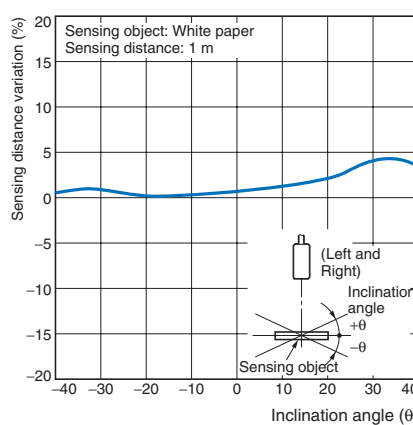

Close-range Characteristics

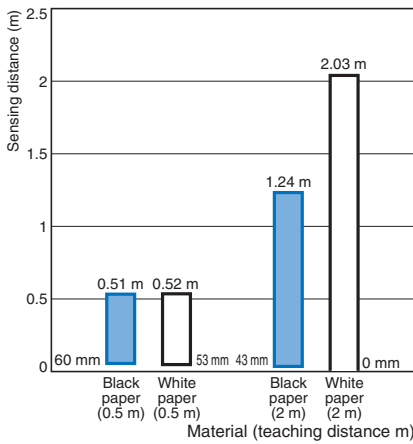

Sensing Distance vs. Sensing Object Material (at 1-m Setting Distance)

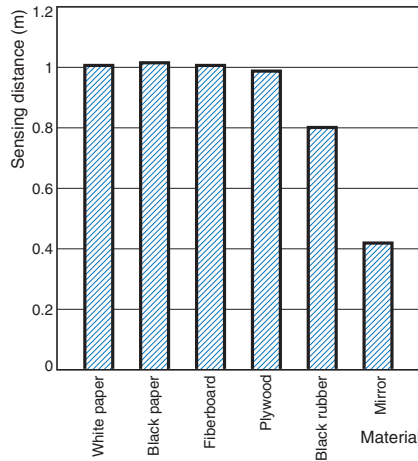

Sensing Distance vs. Sensing Object Material (at 500-mm Setting Distance)

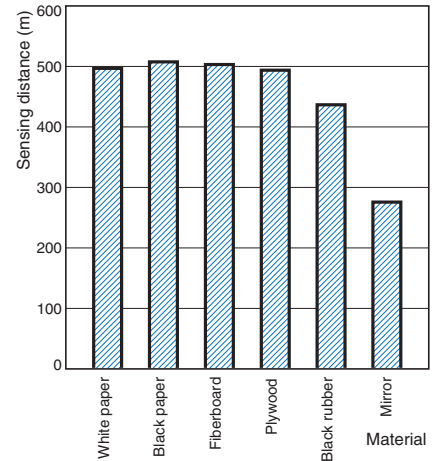

I/O Circuit Diagrams

NPN Output

Model	Operation mode	Timing charts	Operation selector	Output circuit
E3G-R13 E3G-R17 E3G-L73 E3G-L77	Light-ON	Incident light: ON No incident light: OFF Operation indicator (orange): OFF Output transistor: ON Load Operate (relay): OFF Reset: OFF	L side (L-ON)	<p>* Set the NPN or PNP selector to NPN.</p> <p>Connector Pin Arrangement</p> <p>Pin 2 is not used.</p>
	Dark-ON	Incident light: ON No incident light: OFF Operation indicator (orange): OFF Output transistor: ON Load Operate (relay): OFF Reset: OFF	D side (D-ON)	

PNP Output

Model	Operation mode	Timing charts	Operation selector	Output circuit
E3G-R13 E3G-R17 E3G-L73 E3G-L77	Light-ON	Incident light: ON No incident light: OFF Operation indicator (orange): OFF Output transistor: ON Load Operate (relay): OFF Reset: OFF	L side (L-ON)	<p>* Set the NPN or PNP selector to PNP.</p> <p>Connector Pin Arrangement</p> <p>Pin 2 is not used.</p>
	Dark-ON	Incident light: ON No incident light: OFF Operation indicator (orange): OFF Output transistor: ON Load Operate (relay): OFF Reset: OFF	D side (D-ON)	

Relay Output

Timer function	Model	Timing charts	Operation selector	Output circuit
None	E3G -MR19 E3G -ML79		L side (L-ON)	
			D side (D-ON)	
Yes	E3G -MR19T E3G -ML79T		L side (L-ON)	
			D side (D-ON)	

Note: Td1, Td2: Delay time (0 to 5 s)

T1: A period longer than the delay time.

T2: A period shorter than the delay time.

* For ON- and OFF-delay timers, Td1 and Td2 are independently variable.

Plug (Sensor I/O Connector)

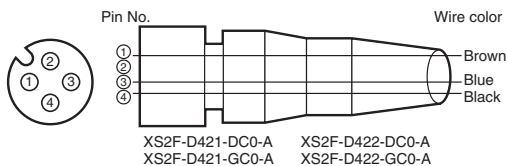

Classification	Wire color	Connector pin No.	Application
DC	Brown	1	Power supply (+V)
	---	2	---
	Blue	3	Power supply (0 V)
	Black	4	Output

Note: Pin 2 is not used.

Nomenclature

Retro-reflective

E3G-R13 (Pre-wired Model)

E3G-R17 (Standard Connector Model)

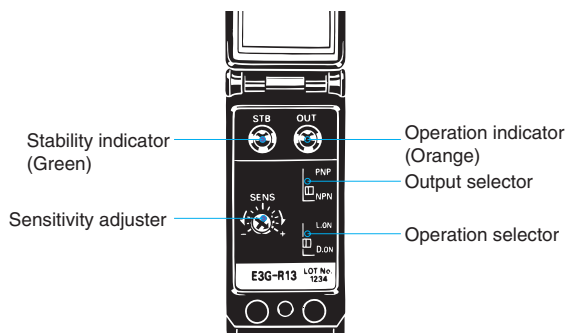

Distance-setting

E3G-L73 (Pre-wired Model)

E3G-L77 (Standard Connector Model)

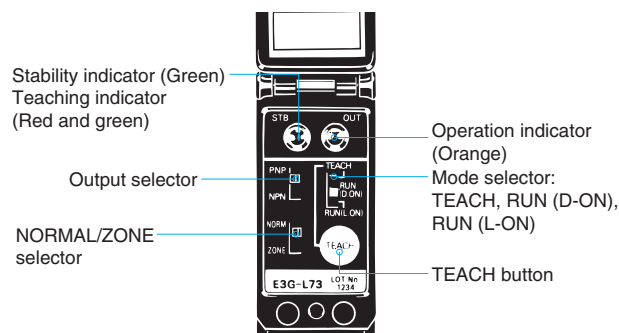

E3G-MR19 (Terminal Block Model)

E3G-MR19T (Terminal Block Model with Timer)

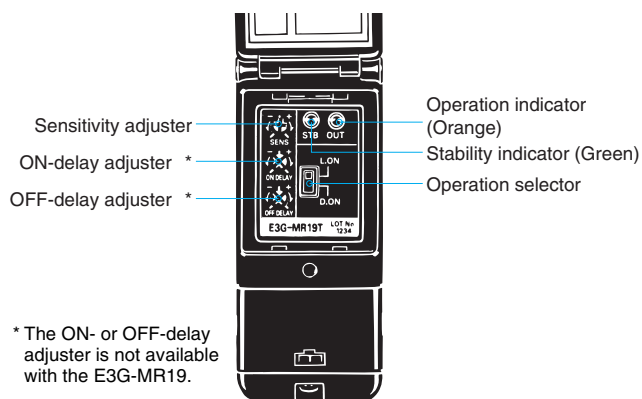

E3G-ML79 (Terminal Block Model)

E3G-ML79T (Terminal Block Model with Timer)

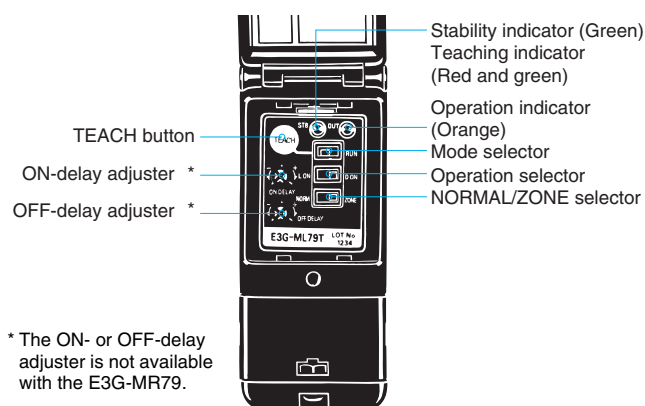

Safety Precautions

Refer to *Warranty and Limitations of Liability*.

⚠ WARNING

This product is not designed or rated for ensuring safety of persons either directly or indirectly. Do not use it for such purposes.



Precautions for Correct Use

Do not use the product in atmospheres or environments that exceed product ratings.

E3G-R/MR

● Designing

Power Supply

A power supply with full-wave rectification can be connected to the E3G-MR19(T).

● Wiring

The tensile strength of the cable during operation should not exceed the values shown below.

Model	Tensile strength (torque)
E3G-R13 E3G-MR19(T)	50 N max.
E3G-R17	10 N max.

● Adjusting

Indicators

- The following illustration indicates the operating levels of the E3G.
- Set the E3G so that it will work within the stable operation range.

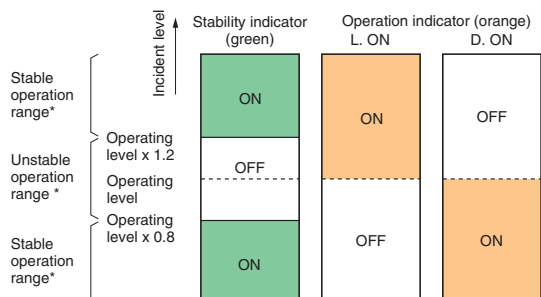

*If the operating level is set to the stable operation range, the E3G will operate with the highest reliability and without being influenced by temperature change, voltage fluctuation, dust, or setting change. If the operating level cannot be set to the stable operation range, pay close attention to environmental changes while operating the E3G.

E3G-L/ML

● Designing

Power Supply

A power supply with full-wave rectification can be connected to the E3G-ML79(T).

● Wiring

The tensile strength of the cable during operation should not exceed the values shown below.

Model	Tensile strength (torque)
E3G-L73 E3G-ML79(T)	50 N max.
E3G-L77	10 N max.

● Mounting

Mounting

Mounting Directions

- Make sure that the sensing side of the Sensor is parallel with the surface of each sensing object. Do not incline the Sensor towards the sensing object.

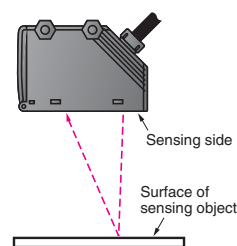

- If the sensing object has a glossy surface, incline the Sensor by 5° to 10° as shown below, provided that the Sensor is not influenced by any background objects.

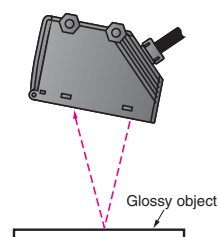

- If there is a mirror-like object below the Sensor, the Sensor may not be in stable operation. Therefore, incline the Sensor or keep the Sensor a distance away from the mirror-like object as shown below.

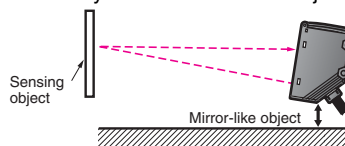

- Make sure not to install the Sensor in the incorrect direction. Refer to the following.

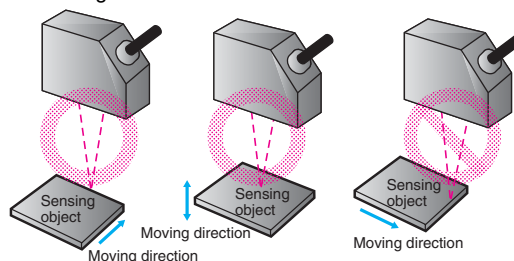

Install the Sensor as shown in the following if each sensing object greatly differs in color or material.

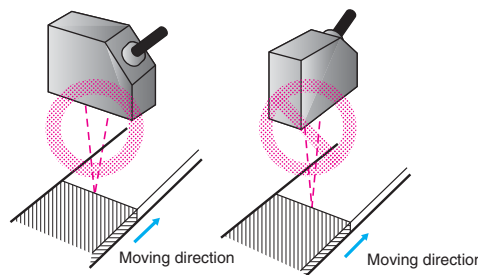

● Others

EEPROM Write Errors

If a teaching data error occurs with the operation indicator flashing due to a power failure or static noise, perform the teaching operation of the Sensor again.

E3G-M□(T)

● Wiring

- The cable with an external diameter of 6 to 8 mm is recommended.
- Be sure to attach the cover with screws securely in order to maintain the water- and dust-resistive properties of the product. The size of the conduit opening is PF1/2 in accordance with JIS B0202.
- Do not tighten the Terminal Protection Cover with wires pinched between the Sensor and the cover in order to maintain the water- and dust-resistive properties of the product.

Recommended Example

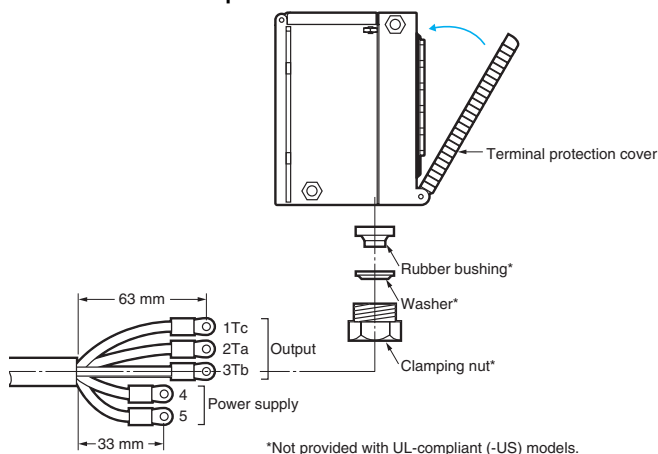

● Changing to Side-pullout Cable from Vertical-pullout Cable

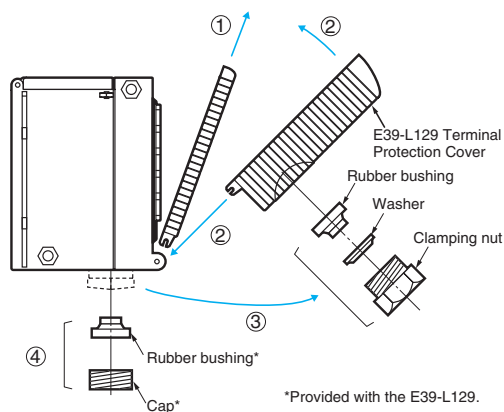

Procedure	Operation
1	Remove the present cover.
2	Attach the E39-L129 Terminal Protection Cover for side-pullout cable.
3	Remove the clamping nut, washer, and rubber bushing of the E3G. These are used for the side-pullout cable.
4	Attach the rubber bushing and cap provided with the E39-L129 to the E3G as replacements.

All E3G Models

● Designing

Load Relay Contact

If E3G is connected to a load with contacts that spark when the load is turned OFF (e.g., a contactor or valve), the normally-closed side may be turned ON before the normally-open side is turned OFF or vice-versa. If both normally-open output and normally-closed output are used simultaneously, apply a surge suppressor to the load. Refer to *OMRON's PCB Relays Catalog (X33)* for typical examples of surge suppressors.

● Wiring

Connecting and Wiring

The E3G has a built-in function to protect the E3G from load shortcircuiting. If load shortcircuiting results, the output will be turned OFF. In that case, check the wiring and turn ON the E3G again so that the short-circuit protection circuit will be reset. This function will operate if the output current flow is at least 2.0 times the rated load current. If a capacitive load is connected to the E3G, make sure that the inrush current does not exceed 1.2 times the rated load current.

● Mounting

Mounting Conditions

- If Sensors are mounted face-to-face, make sure that no optical axes cross each other. Otherwise, mutual interference may result.
- Be sure to install the Sensor carefully so that the directional angle range of the Sensor will not be directly exposed to intensive light, such as sunlight, fluorescent light, or incandescent light.
- Do not strike the Photoelectric Sensor with a hammer or any other tool during the installation of the Sensor, or the Sensor will lose its water-resistive properties.
- Use M4 screws to mount the Sensor.
- When mounting the case, make sure that the tightening torque applied to each screw does not exceed 1.2 N·m.

● Water Resistance

Tighten the operation cover screws and terminal block cover screws to a torque of 0.3 to 0.5 N·m in order to ensure water resistivity.

Distance-setting Models

Pre-wired Model
E3G-L73

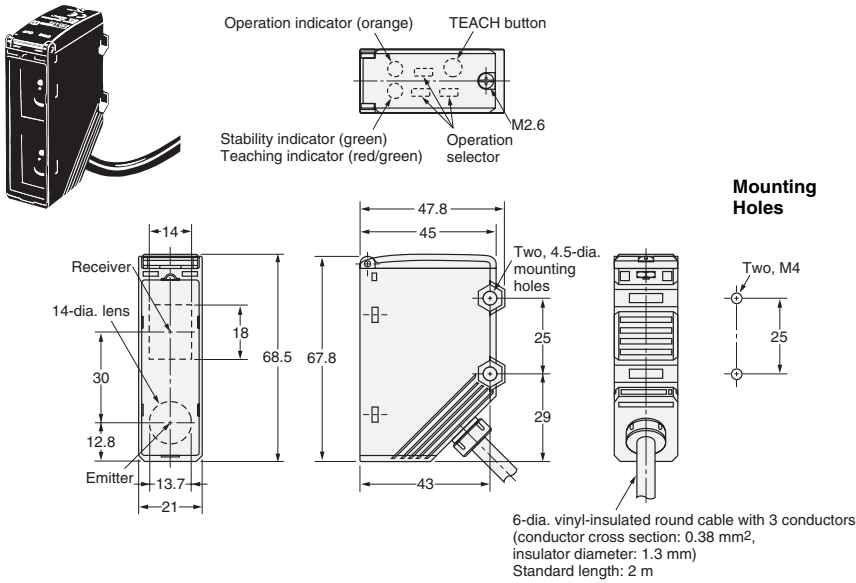

Standard Connector Model
E3G-L77

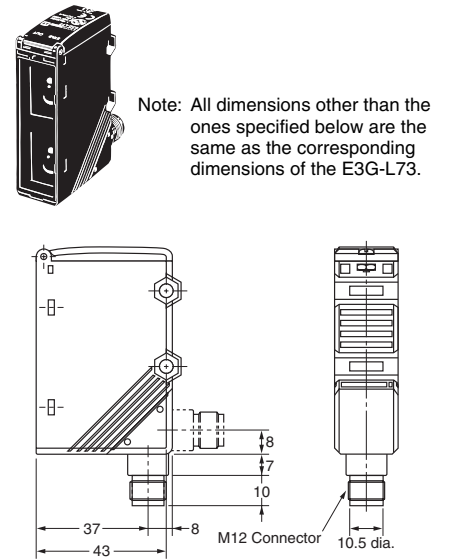

Terminal Block Models
E3G-ML79
E3G-ML79T

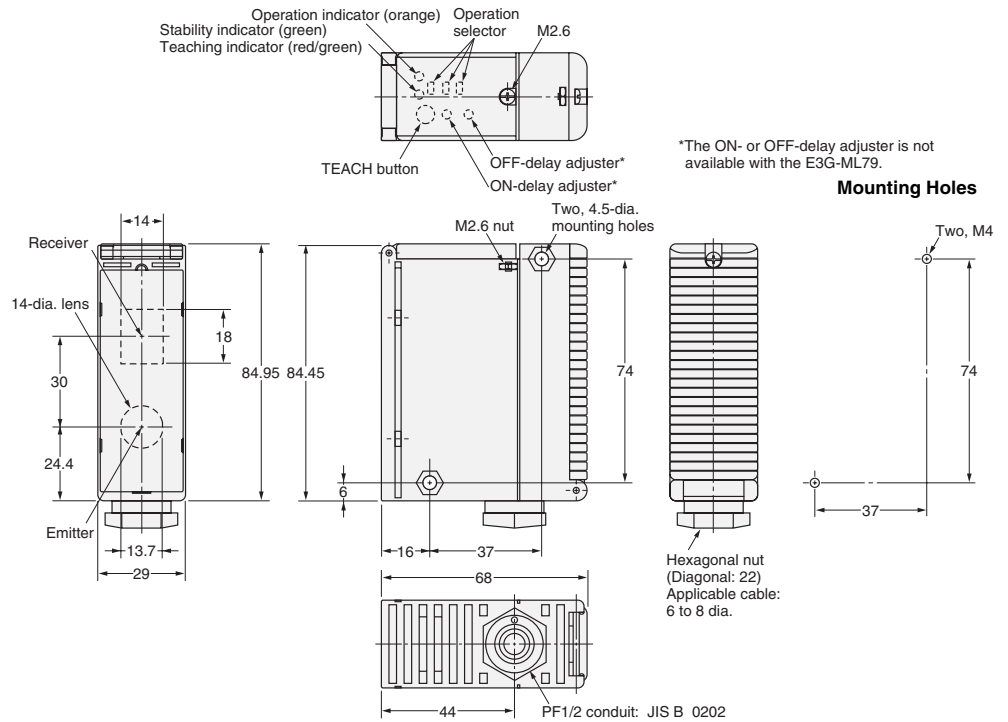

Accessories (Order Separately)

Terminal Protection Cover for Side-pullout Cable

E39-L129

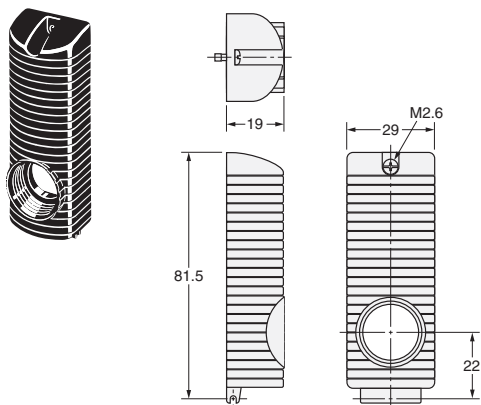

- Note: 1. The cover is provided with a rubber bushing and cap to prevent the cable from being pulled out vertically.
 2. Refer to page 9 for the mounting method of the product.

Terminal Protection Cover for Side-pullout Cable

(Example: E3G-MR19)

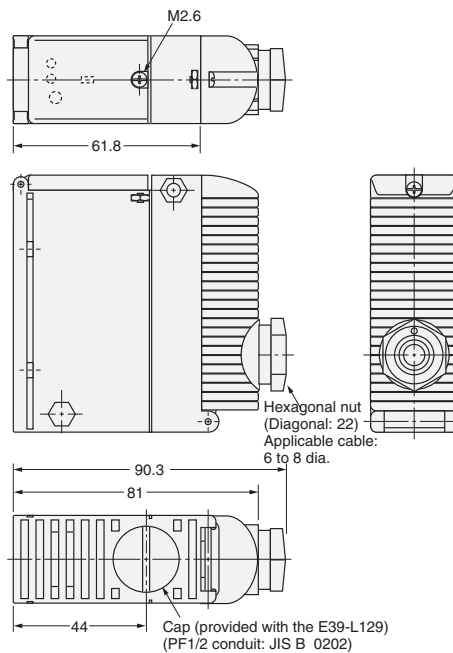

Reflectors

Refer to *E39-L/F39-L/E39-S/E39-R* for details.

Mounting Brackets

Refer to *E39-L/F39-L/E39-S/E39-R* for details.

Sensor I/O Connectors

Refer to *Introduction to Sensor I/O Connectors* for details.

Read and Understand This Catalog

Please read and understand this catalog before purchasing the products. Please consult your OMRON representative if you have any questions or comments.

Warranty and Limitations of Liability

WARRANTY

OMRON's exclusive warranty is that the products are free from defects in materials and workmanship for a period of one year (or other period if specified) from date of sale by OMRON.

OMRON MAKES NO WARRANTY OR REPRESENTATION, EXPRESS OR IMPLIED, REGARDING NON-INFRINGEMENT, MERCHANTABILITY, OR FITNESS FOR PARTICULAR PURPOSE OF THE PRODUCTS. ANY BUYER OR USER ACKNOWLEDGES THAT THE BUYER OR USER ALONE HAS DETERMINED THAT THE PRODUCTS WILL SUITABLY MEET THE REQUIREMENTS OF THEIR INTENDED USE. OMRON DISCLAIMS ALL OTHER WARRANTIES, EXPRESS OR IMPLIED.

LIMITATIONS OF LIABILITY

OMRON SHALL NOT BE RESPONSIBLE FOR SPECIAL, INDIRECT, OR CONSEQUENTIAL DAMAGES, LOSS OF PROFITS OR COMMERCIAL LOSS IN ANY WAY CONNECTED WITH THE PRODUCTS, WHETHER SUCH CLAIM IS BASED ON CONTRACT, WARRANTY, NEGLIGENCE, OR STRICT LIABILITY.

In no event shall the responsibility of OMRON for any act exceed the individual price of the product on which liability is asserted.

IN NO EVENT SHALL OMRON BE RESPONSIBLE FOR WARRANTY, REPAIR, OR OTHER CLAIMS REGARDING THE PRODUCTS UNLESS OMRON'S ANALYSIS CONFIRMS THAT THE PRODUCTS WERE PROPERLY HANDLED, STORED, INSTALLED, AND MAINTAINED AND NOT SUBJECT TO CONTAMINATION, ABUSE, MISUSE, OR INAPPROPRIATE MODIFICATION OR REPAIR.

Application Considerations

SUITABILITY FOR USE

OMRON shall not be responsible for conformity with any standards, codes, or regulations that apply to the combination of products in the customer's application or use of the products.

At the customer's request, OMRON will provide applicable third party certification documents identifying ratings and limitations of use that apply to the products. This information by itself is not sufficient for a complete determination of the suitability of the products in combination with the end product, machine, system, or other application or use.

The following are some examples of applications for which particular attention must be given. This is not intended to be an exhaustive list of all possible uses of the products, nor is it intended to imply that the uses listed may be suitable for the products:

- Outdoor use, uses involving potential chemical contamination or electrical interference, or conditions or uses not described in this catalog.
- Nuclear energy control systems, combustion systems, railroad systems, aviation systems, medical equipment, amusement machines, vehicles, safety equipment, and installations subject to separate industry or government regulations.
- Systems, machines, and equipment that could present a risk to life or property.

Please know and observe all prohibitions of use applicable to the products.

NEVER USE THE PRODUCTS FOR AN APPLICATION INVOLVING SERIOUS RISK TO LIFE OR PROPERTY WITHOUT ENSURING THAT THE SYSTEM AS A WHOLE HAS BEEN DESIGNED TO ADDRESS THE RISKS, AND THAT THE OMRON PRODUCTS ARE PROPERLY RATED AND INSTALLED FOR THE INTENDED USE WITHIN THE OVERALL EQUIPMENT OR SYSTEM.

PROGRAMMABLE PRODUCTS

OMRON shall not be responsible for the user's programming of a programmable product, or any consequence thereof.

Disclaimers

CHANGE IN SPECIFICATIONS

Product specifications and accessories may be changed at any time based on improvements and other reasons.

It is our practice to change model numbers when published ratings or features are changed, or when significant construction changes are made. However, some specifications of the products may be changed without any notice. When in doubt, special model numbers may be assigned to fix or establish key specifications for your application on your request. Please consult with your OMRON representative at any time to confirm actual specifications of purchased products.

DIMENSIONS AND WEIGHTS

Dimensions and weights are nominal and are not to be used for manufacturing purposes, even when tolerances are shown.

PERFORMANCE DATA

Performance data given in this catalog is provided as a guide for the user in determining suitability and does not constitute a warranty. It may represent the result of OMRON's test conditions, and the users must correlate it to actual application requirements. Actual performance is subject to the OMRON Warranty and Limitations of Liability.

ERRORS AND OMISSIONS

The information in this document has been carefully checked and is believed to be accurate; however, no responsibility is assumed for clerical, typographical, or proofreading errors, or omissions.

2009.5

In the interest of product improvement, specifications are subject to change without notice.

OMRON Corporation
Industrial Automation Company

<http://www.ia.omron.com/>

(c)Copyright OMRON Corporation 2009 All Right Reserved.